

HYDRAULIC THROTTLE CONTROL INSTALLATION/ADJUSTMENTS

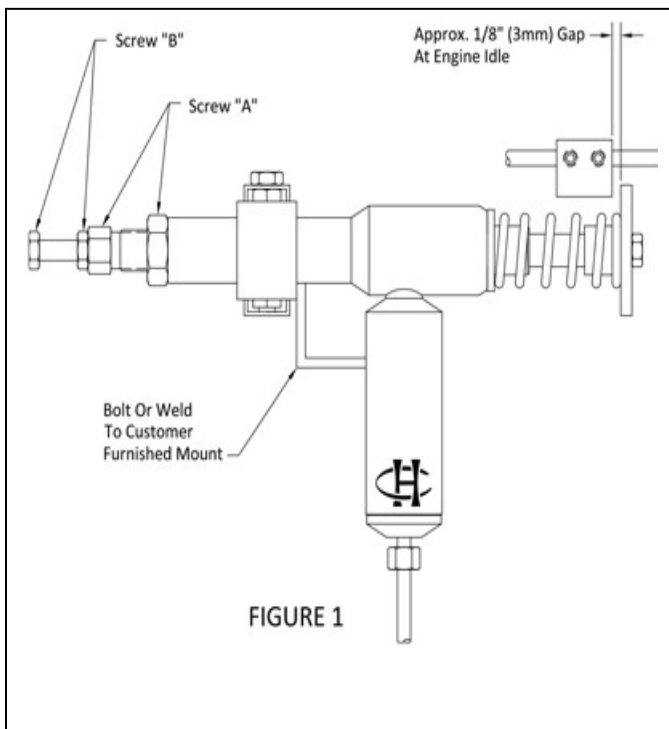
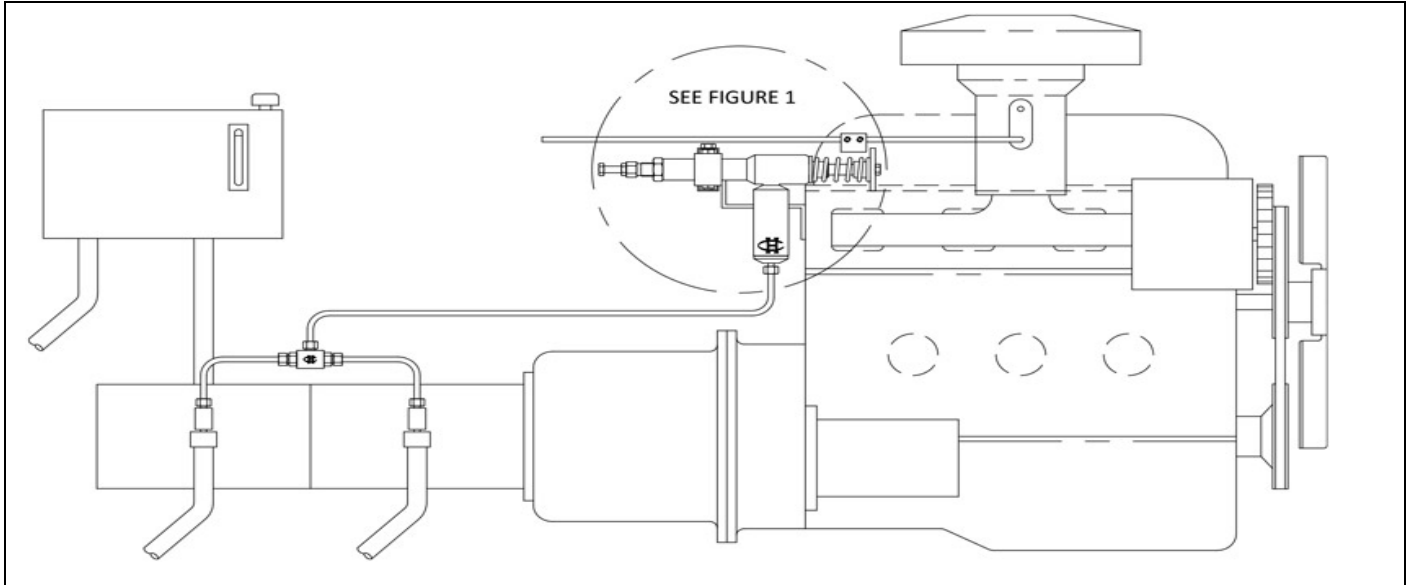

ADJUSTMENTS:

PRESSURE ADJUSTING SCREW "A"

1. Turn in if engine will not return to idle after work cycle. For maximum performance, do not adjust in more than absolutely necessary.
2. Turn out if engine will not accelerate at start of work cycle. If piston cannot be pushed in manually, back out screw "B" also.

STROKE ADJUSTING SCREW "B"

1. Turn in to slow engine speed during work cycle.
2. Turn out to increase engine speed during work cycle.

ACCELERATOR ROD CLAMP ADJUSTMENT

1. Approximately 1/8" gap between accelerator rod clamp and throttle control.

AFTER MAKING FINAL ADJUSTMENTS TIGHTEN LOCK ALL LOCK NUTS.

CAUTION: Do not drive vehicle with hydraulic pump engaged when the throttle control is included as part of the system. (See Level 2)

NOTES

Part number 2145 includes throttle control, accelerator rod clamp, and weld tube clamp. A 2114 shuttle valve will be required when two (2) pumps are used. Another shuttle valve will be necessary for each additional pump.
Maximum Operating Pressure 2,000 P.S.I.